



ORANGE WHEAT BLOSSOM MIDGE MONITORING KIT

This easy to use trap is designed to catch adult Orange Wheat Blossom Midges. It is a valuable and cost effective tool in determining the likelihood of serious midge attack and makes assessment of the risk of attack much more straightforward. The male adults are attracted to the female sex pheromone contained in a rubber septum and become stuck on the glue surface. Using the trap makes it easier to find the insect. Recent research has led to guidelines as when action should be taken and full advice and information can be found at www.agrisense.co.uk.

About the Pest

Before now, the only way to be sure which crops are at risk from Orange Wheat Blossom Midge (*Sitodiplosis mosellana*) has been to check all crops each evening through the ear emergence period, whenever conditions seem suitable for an insect flight. The practical difficulty in doing this has resulted in many serious infestations being overlooked.

Wheat Blossom Midge (*Sitodiplosis mosellana*) larvae hibernate in the soil and can remain dormant for five years or more. The numbers that pupate each year, (there is only one generation egg to adult per year) and produce adult midges, depends on the soil temperature and rainfall during May and early June. The local degree of wetness can vary greatly due to soil type, drainage and the track of passing showers. Thunderstorms tend to stimulate a mass hatch that occurs about a week afterwards and their localised nature can lead to a high variability in risk.

Once the adult midges have hatched, the male midges mate with females hatching in the same field and die. The female midges then fly on suitable evenings over the next one or two weeks, seeking vulnerable crops in which to lay their eggs. If a flush of emergence coincides with the susceptible stage of a particular crop it may be badly damaged, while other crops nearby, emerging a few days earlier or later may escape. The susceptible stage covers the ear emergence period between GS51 and GS59. Larvae from eggs laid from GS61 onwards fail to develop properly due to the increasing toxicity of the developing grain. A large return of larvae to the soil poses the risk of severe damage reappearing should conditions again favour the pest. The areas most affected shift each year due to local weather patterns.

Easiset Delta Trap Kit Contents

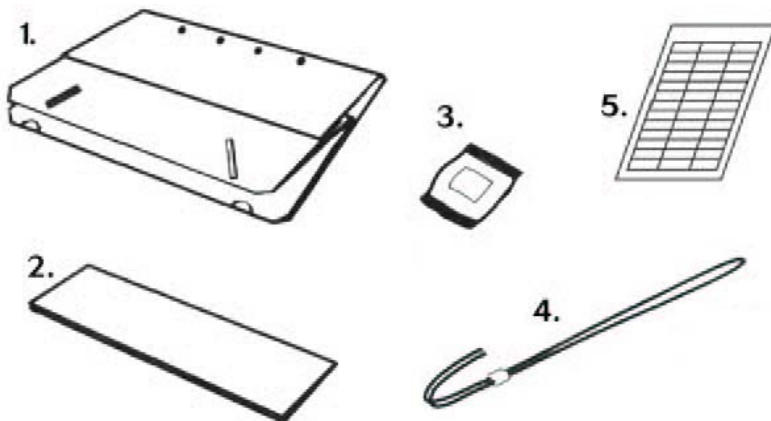

1. Delta Trap x 2
2. Sticky Insert x 8
3. Foil sachet x 2
(containing pheromone lure)
4. Wire hanger x 2
5. Trapping Record Card

Trap Assembly

The Easiset Delta Trap has a triangular cross section and is made of folded plastic. The insects are attracted by the incorporated pheromone lure, enter the trap and are caught on the non drying glue insert. This can later be removed for inspection and replacement.

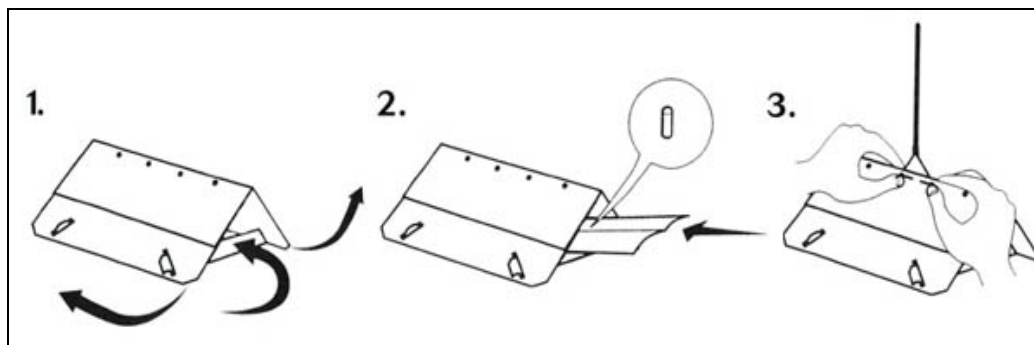

1. Unfold the trap and form a delta shape by inserting the tabs at one end into the slots.
2. Fold open the sticky glue insert, open the silver foil sachet and remove the white rubber septum.
3. Place the lure on the centre of the sticky surface so that it is stuck to the glue. Do not squeeze or cut the lure in any way.
4. Place the sticky insert into the trap, glue side up and fold the remaining end into the slots.
5. Open out the hooked end of the wire hanger, place in the holes in the centre of the trap and fold back.
6. Attach the wire to a stake and place it in the crops and inspect regularly.
7. Additional glue cards are provided. When the cards are full of insects, replace the card. Move the pheromone lure from the old card onto the new glue card surface.

Trap Placement

Put traps in place one week before the first ears emerge. Traps should be placed in current wheat field if significant levels of attack were noted when last in wheat. If the field has not recently been in wheat then traps should be placed in those previous year's wheat fields that represented the most likely sources of infestation.

It is recommended that this is done at GS45, when the boots are swollen. Leave traps in position until all crops in the vicinity reach flowering (GS61). Adult midges normally emerge between the last week of May and the first week of June, with the main emergence period in early June. Traps should be attached to stakes at the same height or just below the ears. A minimum of two traps should be used in each field, regardless of its size. In addition, two traps should be placed in each area of the farm with different microclimates. Traps placed in sheltered moist valleys may give different results to more exposed sites.

Lures should last 6 weeks or more and therefore will not need to be changed in the course of one season. It is recommended that at each reading sticky inserts are either swapped for clean ones or the trapped insects and any debris be removed and the glue stirred. The sticky inserts should normally last a season but should be changed if excessively contaminated or rotated to facilitate insect counting. When replacing sticky inserts carefully move the lure from one insert to the next avoiding excess contamination with the glue.

Trap Recording

Catches should be recorded every 2-3 nights on the Trapping Record Card provided. Action threshold for in field-assessment and potential treatment should vary with weather. 20-30 midges in any two night period would suggest that there is a risk to susceptible crops in the vicinity if weather is warm and settled (above 15°C at 20:00 hours with low wind speed). The threshold of can be up to 100 midges if weather conditions are marginal and some OWBM activity is noted. Threshold applies to highest catch in either current wheat field or an adjoining source.

Storage and Handling Recommendations

The pheromone dispensers are supplied in labelled and batch coded vapour proof sachets. The sachets should be kept at good storage conditions. Kept below 15°C, the dispensers will retain their efficacy for a minimum of 12 months. Bulk storage of dispensers for periods of up to 18 months is possible by refrigeration at temperatures of 4°C or below. Do not store dispensers for more than this time even in a refrigerator. Once removed from the sachet, the pheromone dispensers have a known and declared period of activity. After this time the pheromone dispenser should be removed from the area of use to prevent interference with the fresh replacement/recharge dispenser. There are no special requirements for disposal.